

# Installation Note

## Autoscope® RackVision™ Terra™ Description (Euro Model with 64-Pin Backplane)

The Autoscope RackVision™ Terra video vehicle detection system (RVT) provides digital image processing using an advanced video processor in the form of a single-camera, 3U × 160 mm Euro card. Each RackVision Terra performs vehicle detection, traffic data collection, and incident detection on CCTV video input (PAL, CCIR) for tunnels, junctions, and highways. Each RVT provides its own set of I/O ports to enable the RVT to communicate with external devices. The RVT can be used in standalone installations or integrated into existing Autoscope communications networks. The RVT uses EasyLink™ Ethernet communications. It has two component parts: the RackVision Terra (Figure 1-1), and the RackVision Backplane (Figure 1-2)

You may set up the RVTs using the standard Autoscope Windows interface to create more than 50 virtual detection zones for count, speed, vehicle presence, and incident-detection applications. You may also configure the RVT via a web interface.



**Figure 1-1. RackVision Terra**

The RackVision Backplane uses a 64-pin DIN connector. The backplane provides the

following features:

**Table 1-1. System Part Numbers and Descriptions**

<b>Backplane Feature</b>	<b>600285 64-Pin</b>
Power Connections	2
Video Input	1
Video Output	1
Signal Inputs	4
Detector Outputs	8
Status Output	1
Logic Ground Connection	None <sup>1</sup>
Ethernet RJ-45 Connection	None <sup>2</sup>
Detector Port Connections (DET+, DET-)	2
SMA to BNC Coaxial Adapter Cables	2
Bussing Connector for Serial bus, Detector Port, AC interrupt, GND	10-pin

The detector port connections are for use between multiple backplanes and an optional Detector Port Master product such as the Detector Rack Card.

---

<sup>1</sup> Use V- on power connector instead.

<sup>2</sup> Use connection on the front of the Terra RackVision for Ethernet.

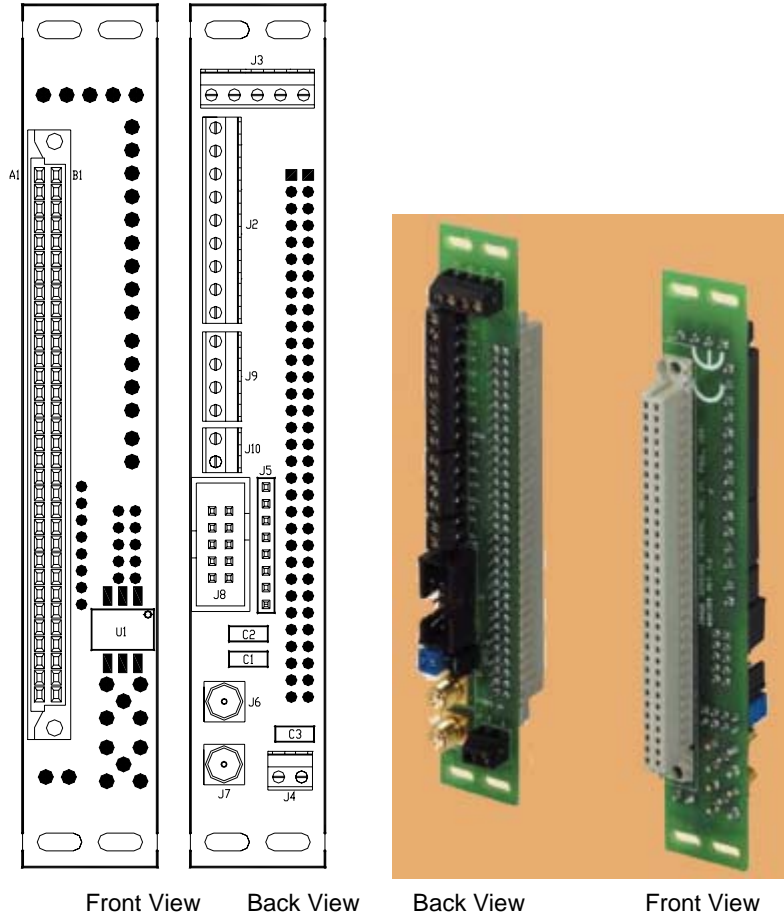

**Figure 1-2. RackVision Backplane (64-Pin)**

## Autoscope RackVision Terra Parts and Cables

An Autoscope RackVision Terra ships with two components, the Autoscope Terra RackVision and Autoscope RackVision Backplane (64-pin):

**Table 1-2. System Part Numbers and Descriptions**

ISS Part Number	System Description
600606	Autoscope RackVision Terra with 64-pin connector.
600285	Autoscope RackVision Backplane (for 64-pin connector RVT only).

The RackVision Terra uses the following cables:

**Table 1-3. Cable Part Numbers and Descriptions**

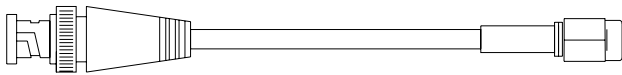
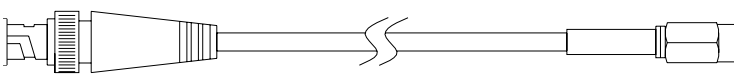
ISS Part Number	Qty	Cable Description
600385	2	<p>Short 457 mm (18 inches) SMA to BNC coaxial cable adapter:</p> 
600387	2	<p>Long 3.81 m (12.5 ft) SMA to BNC coaxial cable adapter:</p> 
Optional NA	1	<p>Optional RackVision Backplane bus connectors and ribbon cable:</p> 

## Autoscope RackVision Terra Specifications

Table 1-4. RackVision Terra Specifications

<b>Specifications</b>	
<p><b>Electrical</b></p> <p>Power Supply: 12 to 24 VDC, 11 Watts (maximum)</p> <ul style="list-style-type: none"> <li>▪ Power consumption, current draw: 12 VDC: Basic unit      11 W, 900 mA 24 VDC: Basic unit      11 W, 500 mA</li> </ul>	<p><b>Environmental</b></p> <p>–34° C to +74° C (–29° F to +165° F)</p> <p>0 to 95% relative humidity, non-condensing, over the temperature range</p>
<p><b>Dimensions</b> (Height × Width × Length [3U × 160 mm])</p> <p>130 mm × 20 mm × 191 mm (5.10 in × 0.80 in × 7.50 in)</p>	<p><b>Weight</b></p> <p>0.16 kg (0.35 lb) basic unit</p>
<p><b>Video</b></p> <ul style="list-style-type: none"> <li>• <b>Input:</b> <ul style="list-style-type: none"> <li>▪ Composite 75Ω 1 Vpp, SMA connector on backplane</li> <li>▪ PAL, CCIR, NTSC, or RS170</li> </ul> </li> <li>• <b>Output:</b> <ul style="list-style-type: none"> <li>▪ 1 Vpp, BNC connector on front</li> <li>▪ 1 Vpp, SMA connector on backplane</li> <li>▪ PAL or NTSC</li> <li>▪ MPEG-4 digital streaming video</li> </ul> </li> </ul>	<p><b>Communications</b></p> <ul style="list-style-type: none"> <li>• EasyLink™ Ethernet 10/100 Mb/s communication via RJ-45 connector on front panel. The Ethernet signals can be routed to the back edge connector using jumpers on the card (not supported on 64-pin backplane).</li> <li>• 2 USB 2.0 connectors reserved for future use.</li> <li>• RS-232/485 Serial port, reserved for future use (4-wire, full-duplex) and Detector Port (2-wire, half-duplex) on back via RackVision Backplane.</li> <li>• Standard 2 × 5 header to bus Serial port, reserved for future use, and Detector Port communications between multiple RackVision Terra cards via RackVision Backplane.</li> </ul>
	<p><b>Regulatory:</b></p> <p></p> <p>CE EN 55022, EN 61000-6-1 FCC Part 15, Class A RoHS</p>

## RackVision Front Panel Configuration

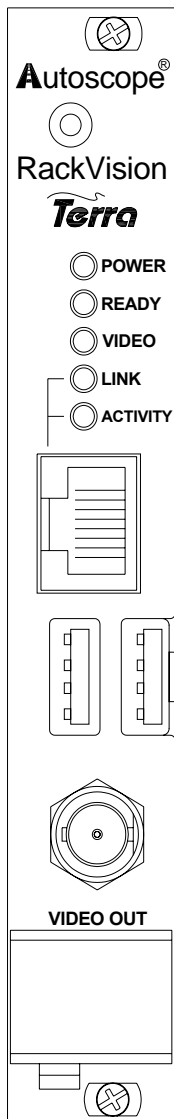

The RackVision front panel provides:

- LED indicators for power, data processing status, valid video, and communications link/activity status.

NOTE. The activity LEDs function independently if each unit has a unique IP address. However, if there is a message that is broadcast to all units, the activity LEDs will light in unison. Two examples of broadcast messages being sent are during Learns, and timeouts on messages sent to the device. When a message sent to a unit times out, the Communications Server resends the message as a broadcast. Instances of this type of broadcast are during a unit reboot or when the Communications Server is getting the mode of the MVP (such as when downloading properties and a configuration. If the MVP is not properly running yet, the attempt to get the mode will time out and the message will get resent as a broadcast.

- EasyLink™ RJ-45 connector for Ethernet communications.
- 2 – USB 2.0 connectors reserved for future use.
- A 1 Vpp composite analog video output for viewing video output via a video monitor.

**Table 1-5. Indicator Functions**

Indicators	Function
<b>POWER</b>	Activates upon power up.
<b>READY</b>	Indicates the RackVision Terra processing software is running.
<b>VIDEO</b>	Indicates presence of good video signal. Composite video inputs (PAL, CCIR, NTSC, or RS170). The RackVision Terra processes signals in real time from one video camera.
<b>LINK</b>	Indicates RackVision Terra has a valid link on the Ethernet connector.

Indicators	Function
<b>ACTIVITY</b>	Indicates RackVision Terra is transmitting or receiving data on the Ethernet connector.

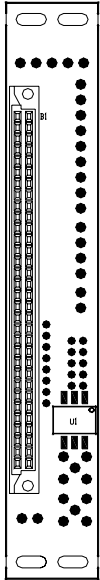

Front View  
(64-pin)

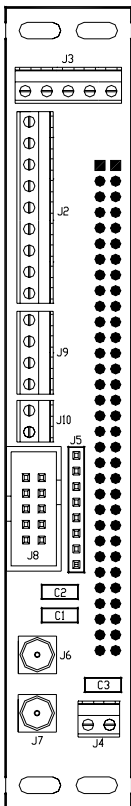

Back View  
(64-pin)

The RackVision Terra Backplane provides the following connectors or terminations. All pinouts are defined in the Appendix:

- **J1** is a standard DIN 41612, Type B, 64-pin VME connector. The RackVision Terra plugs into this connector.
- **J2** For the 64-pin backplane, consists of 9 screw terminal outputs, **O1–O8** and **Status**. All the outputs are open collector, active low. The outputs can be inverted in software to emulate active high outputs. Status output (open collector, active low), when **ON**, indicates the card is operational.
- **J3** consists of 5 screw terminal inputs, **I1–I4** and **AC INT**. The **AC INT** is reserved for the AC interrupt signal, which is used to minimize the RVS Terra clock drift. All the inputs are read in as active low. These inputs are typically used to provide the RED and GREEN signal states to the processor for intersection control applications. Based on these signals, further advanced processing such as delay or extension may be conducted.
- **IMPORTANT NOTE: AC INT** accepts inputs with the voltage range 0 to +5 VDC. Inputs 1 to 4 can accept higher input voltage levels from 0 to 24 VDC. If the user mistakenly applies the higher INPUT voltage to the **AC INT** pin, then the RackVision Terra board will be damaged.
- **J4** provides the power supply screw terminals. Supply voltage may range from 12 to 24 VDC. Positive is connected to **V+** and supply **GND** is connected to **V–**.
- **J5** consists of 4 jumpers that may be used to tell the RVS Terra in which slot it is installed when multiple RackVision Terras are used with a Detector Rack Card or Terra Access Point.
- **J6** is the **Video In** SMA connector. This connector connects to the camera using an SMA-to-BNC cable that connects to the coaxial cable that comes from the camera. You use a male-to-male “barrel” connector to connect the SMA-to-BNC adaptor cable to the camera coaxial cable.
- **J7** is the **Video Out** SMA connector. This connector may be cabled to a video device such as a video switch or monitor. An SMA-to-BNC adaptor cable is provided to enable connection to a coaxial cable with the more common BNC connector. A male-to-male “barrel” connector will be required to connect the two BNC connectors.
- **J8** is a standard 2 × 5 header to bus the Serial port, reserved for future use, and Detector Port communications between multiple RackVision Terras. To interconnect the cards, use the optional Bus Connector and Ribbon Cable. Clamp connectors onto the ribbon cable as needed and connect cards by plugging connectors into headers in sequence. You do not need to terminate the cable if connecting 8 or fewer RackVisions together.
- **J9** is a 4-pin, RS-485, Serial connector that is reserved for future use.
- **J10** is the two-pin, detector port RS-485 **DET+** and **DET–** connection to an optional Autoscope Detector Rack Card in order to supply additional inputs and outputs. This is used when more than 4 inputs or 8 outputs are needed.

## Distribution of Signal Reference or Logic Ground for Rack Systems using Modular RackVision and Detector Rack Cards

Figures 1-3 and 1-4 show multiple Racks that contain multiple devices such as RackVision Terra units and Detector Rack Cards or Terra Access Points for 64-pin backplanes. (The Racks are drawn as viewed from the back.) In each “Rack” are the RackVision Terra and Detector Port Master units as well as a power supply that is seen located on the far right side of each Rack, as a larger rectangle.

Connecting the various devices are lines that represent ONLY the Signal Reference or Logic Ground (referred to in this document as Ground).

- For the 64-pin backplane, this Ground connection is the **V-** terminal of **J4**. Ideally, the connection of individual Grounds for the 64-pin should allow for a single common point at which all Grounds connect. All the Grounds from devices in a Rack return to the Power Supply of that Rack. At the Power Supply, the Grounds from the Power Supplies are connected together.
- One common Ground extends from one of the Racks to an external location that is referred to here as the Signal Reference or Controller Logic Ground.

Figure 1-3 shows the recommended approach for the 64-pin backplane because the Ground current for each individual device returns to the power supply on its own Ground wire.

Figure 1-4 shows an alternative approach for the 64-pin backplane. Here the Ground current for each device returns along all Ground wires for each of its neighbors to the right. The drawback of this alternative approach is that if you measure the voltage difference between the Controller Logic Ground and the Ground at each device in the Rack, you may find that a greater difference is found, the farther from the Power Supply the device is located. In the recommended approach, the voltage difference measured would be the same at each device regardless of its distance from the Power Supply.

If you use the alternative approach for distributing the Grounds, the drawback may be minimized by using a wire of sufficiently large diameter to minimize the resistance.

### Additional Guidelines

In a multi-rack system using 64-pin Backplanes, you must connect Logic Grounds of each Rack Power Supply together as shown in Figure 1-3. Otherwise, Ground noise between the various Power Supplies could cause unexpected and erroneous behavior of the equipment.

Do not connect Power Supply output voltages of separate Racks together.

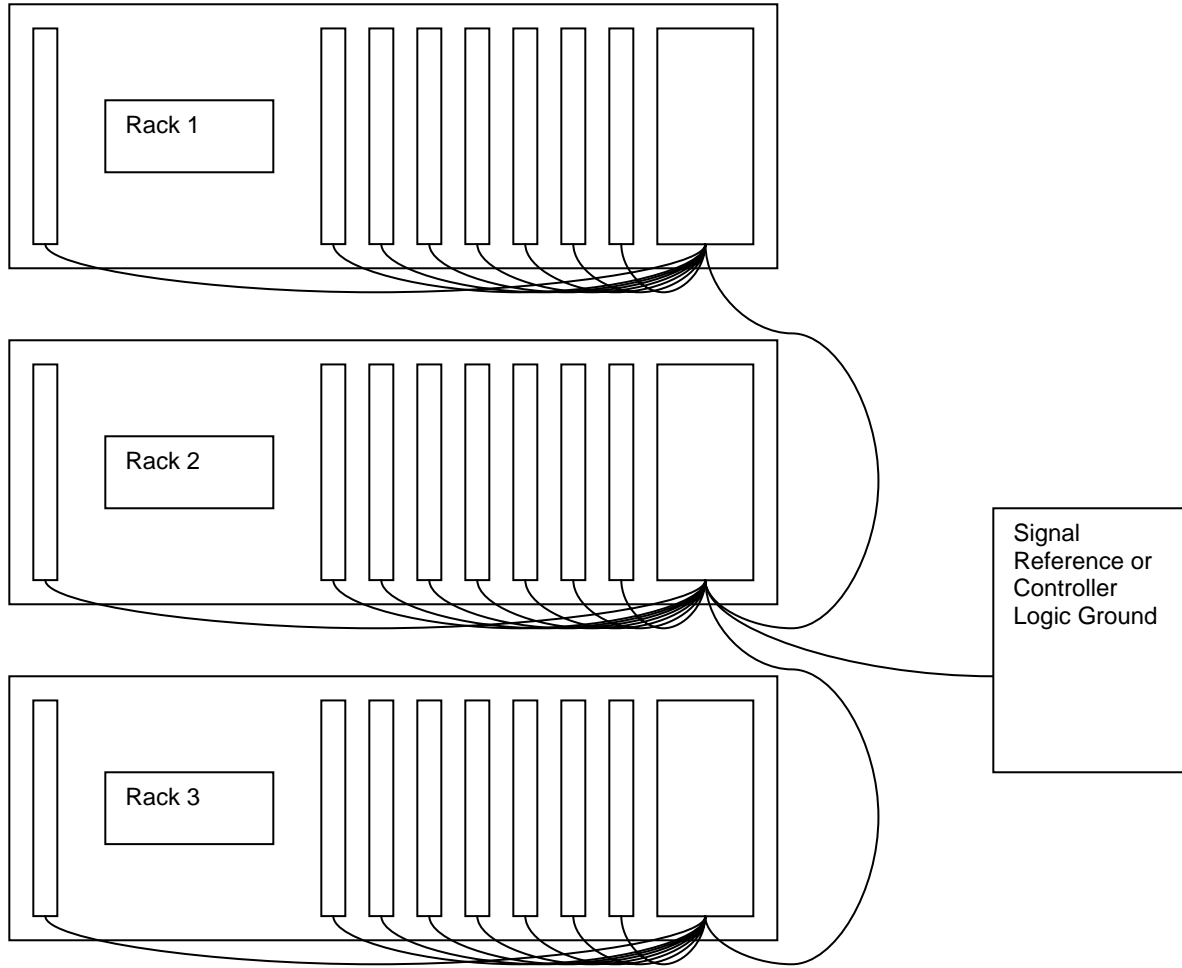

**Figure 1-3. Preferred Approach for Connecting 64-Pin Grounds**

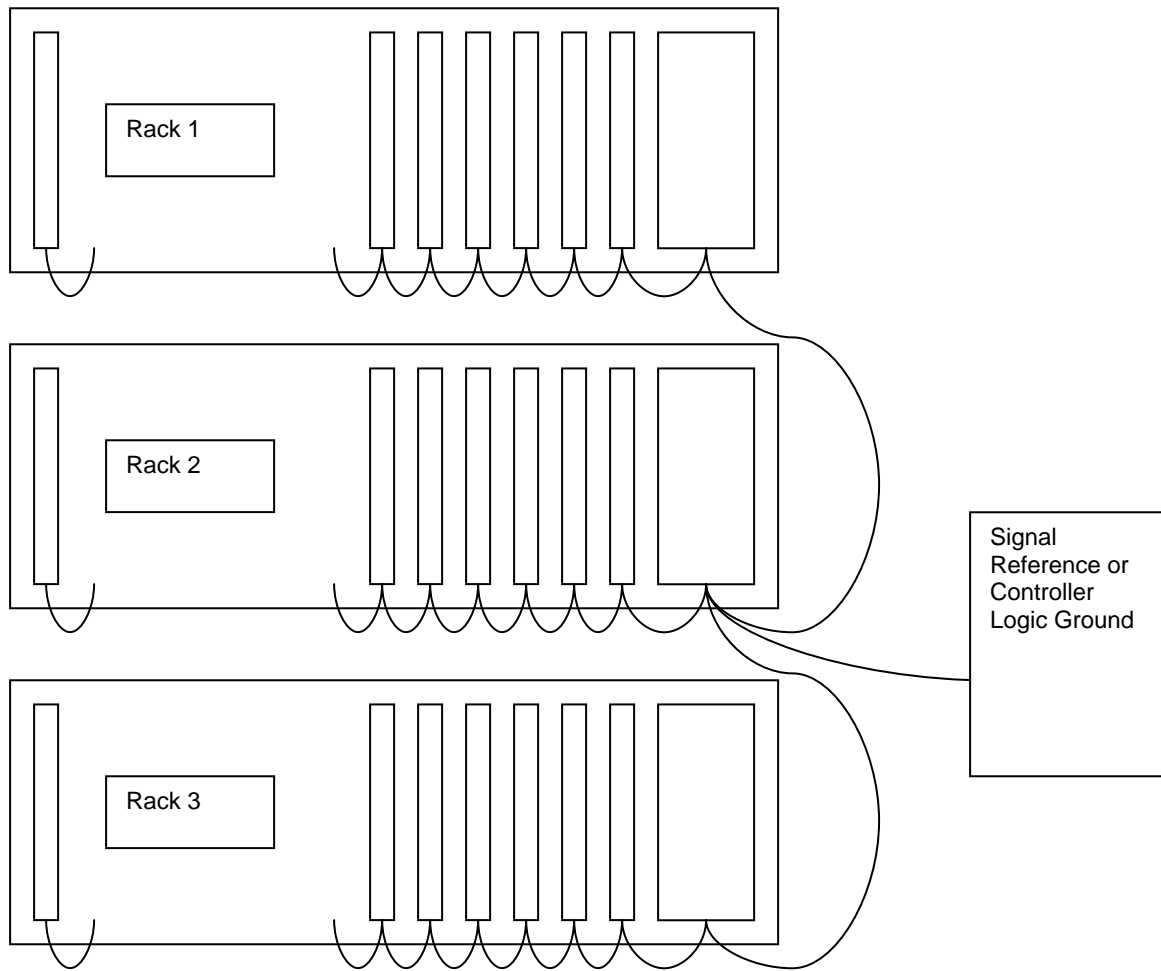

**Figure 1-4. Alternative Approach for Connecting Grounds**

## Installation Procedure



### Caution

As a general rule, you should provide a minimum vertical spacing of 2 cm between Autoscope Racks (and above the topmost rack) that are full of Autoscope RackVision *Terras*. This permits passive circulation of air past the RackVisions in the racks so that they maintain a reasonable operating temperature.

A suitable setup is shown below. This uses a metal baffle to provide spacing and provides sufficient spacing while directing cool air from the front to the cards. Hot air from the rack below is deflected out the back:



### Caution

The RackVision *Terra* card has its own transient protection for power and communications. However, normal transient protection should be installed for the video coming from the camera. For transient device details and installation information, see Providing Video Signal Transient Protection for Coaxial Cable Connections later in this section.



### Warning

**Hazard of damage to personnel or system components.**

**Installing or working with any of these devices with power to the cabinet turned ON may cause injury to personnel or severely damage the RackVision *Terra*, or additional devices connected to it. This is especially true if you have an individual device removed and place your fingers inside any part of the rack where you have removed an individual RackVision *Terra* and you cannot see where you are placing your fingers.**

Ensure that power is turned **OFF** at the cabinet breaker before you touch any installed devices or try to install devices.



**Note**

The Status conditions listed below are under software control and may change as software updates are made.

In general, the Status output pin of the RackVision Terra goes **OFF** if only the pre-detection software (Boot Loader) is running or if there is a severe error. This indicates the RackVision Terra needs to be reset or has failed.

The Status output pin of the RackVision Terra is **ON** as long as the detection software is running. It is used to tell the controller that the software is running. Therefore, the pin is **ON** during normal operation and **OFF** if:

- No detector file is being processed.
- The unit is in surveillance mode.
- The unit is in state block mode to run the System Test application.
- There is no valid video being input to the RackVision Terra.
- There is a severe error.

**Installing the RackVision Terra with a 64-Pin Rear Edge Connector:**

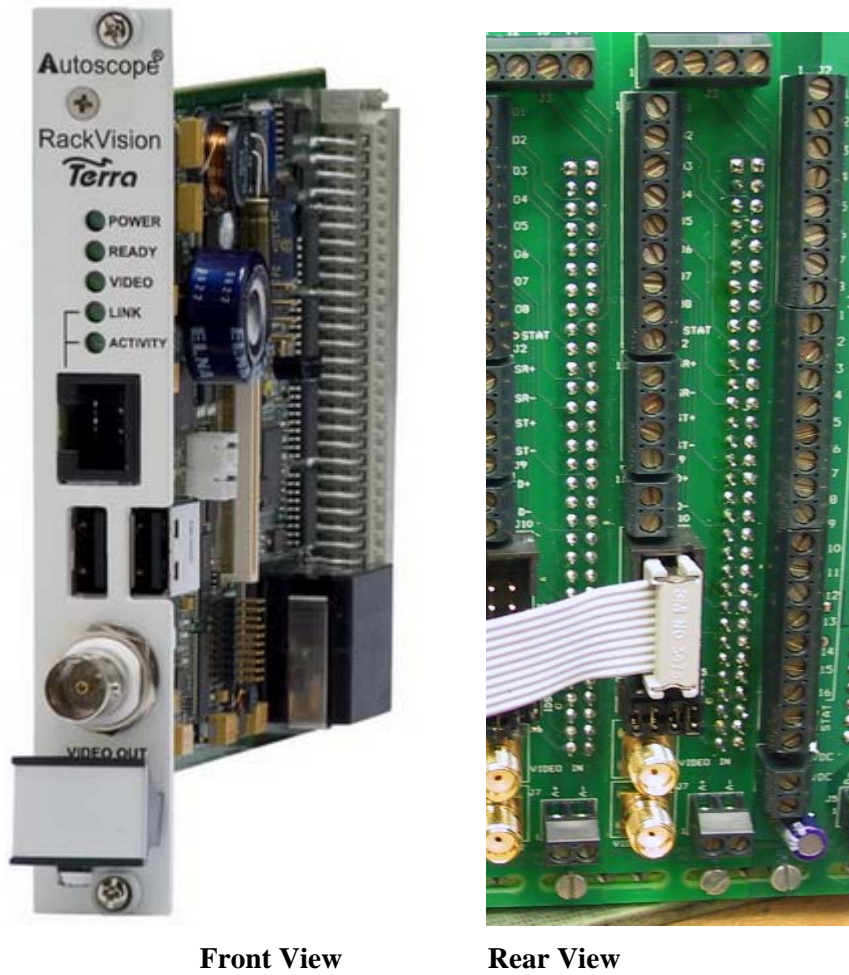

**Figure 1-5. RackVision Terra and RackVision 64-Pin Backplane Views**

To install the RackVision Terra:



Rev A and Rev B RackVision Terra board jumpers are different; the Rev B boards have additional jumpers. Check the revision level of your board. Additional jumpers for the Rev B board are identified as such in the documentation below.

1. Check that the RackVision Terra jumper options are correctly set for your system. Jumper settings are different for the 64-pin and 96-pin backplanes.
  - **Voltage Input Threshold** signals. This jumper must be in one of the following position for proper system operation. I/O Voltage input threshold defaults to 24 VDC. Jumper **J12** positions are as follows (on front panel board). Pin number 1 is on the right. Pin number 3 is on the left in the drawing provided below. The default position for **J12** is pins 1-2:
    - **+24 VDC** input signals: leave jumper **J12** on pins **1-2**.
    - **+12 VDC** input signals: move jumper **J12** from pins **1-2** to pins **2-3**.

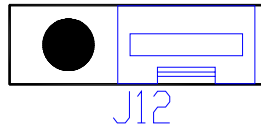

2. **With each of these configurations except for the last group, a set of 4 jumpers moves together for each configuration.** The default configurations are shown in the drawings and photographs provided below.  
Set jumpers **JP32** to **JP39** for the Rev A and Rev B 64-pin backplane as follows:

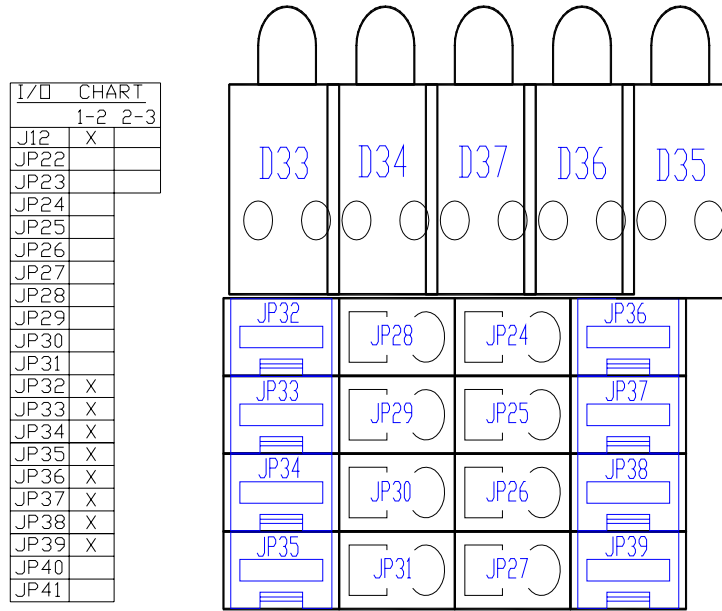

**Figure 1-6. Ethernet Configuration Jumpers for Rev A Boards**



**Note**

For the following three Ethernet setups, only one of the following three Ethernet connections should be enabled at any time. Ethernet signals may be routed only out of the front edge connector when using the 64-pin backplane.

- **Ethernet to Back Edge Connector.** **ETHERNET** signals may be routed to the back edge connector. This feature is supported only with the 96-pin backplane which has an RJ-45 Ethernet connector to support this option. To route these signals to the back edge connector, you must install the jumpers to turn **ON** to the connection. These come in the **OFF** position (no jumper in place).
  - **Ethernet TX+** install jumper **JP24** on pins **1-2**.
  - **Ethernet TX–** install jumper **JP25** on pins **1-2**.
  - **Ethernet RX+** install jumper **JP26** on pins **1-2**.
  - **Ethernet RX–** install jumper **JP27** on pins **1-2**.

- **Ethernet to RS-485 Connector.** This feature is currently not supported.
- **Ethernet to Front Panel RJ-45.** **ETHERNET** signals are routed via the RJ-45 connector located on the front panel of the Terra RackVision card. To route these signals, you must install the jumpers to turn **ON** to the connection. These come in the **ON** position (jumpers in place):
  - **Ethernet TX+** install jumper **JP32** on pins **1-2**.
  - **Ethernet TX–** install jumper **JP33** on pins **1-2**.
  - **Ethernet RX+** install jumper **JP34** on pins **1-2**.
  - **Ethernet RX–** install jumper **JP35** on pins **1-2**.



**Note**

If you are going to send Ethernet signals out the RS-485 connector, you cannot send serial RS-485 signals out the same connector.

- **RS-485 to RS-485 Connector.** This is the old Supervisor port now reserved for future use, which is a set of full duplex RS-485 multi-drop signals that are not supported in the Terra design. These come in the **ON** position (jumpers in place):
  - **TXD+** install jumper **JP36** from pins **1-2**.
  - **TXD–** install jumper **JP37** from pins **1-2**.
  - **RXD+** install jumper **JP38** from pins **1-2**.
  - **RXD–** install jumper **JP39** from pins **1-2**.
- Jumpers for the Rev B board (not present on the Rev A board):

I/O	CHART	
	1-2	2-3
J12	X	
JP22		
JP23		
JP24		
JP25		
JP26		
JP27		
JP28		
JP29		
JP30		
JP31		
JP32	X	
JP33	X	
JP34	X	
JP35	X	
JP36	X	
JP37	X	
JP38	X	
JP39	X	
JP40		
JP41		
JP42	X	
JP43	X	
JP44	X	
JP45	X	

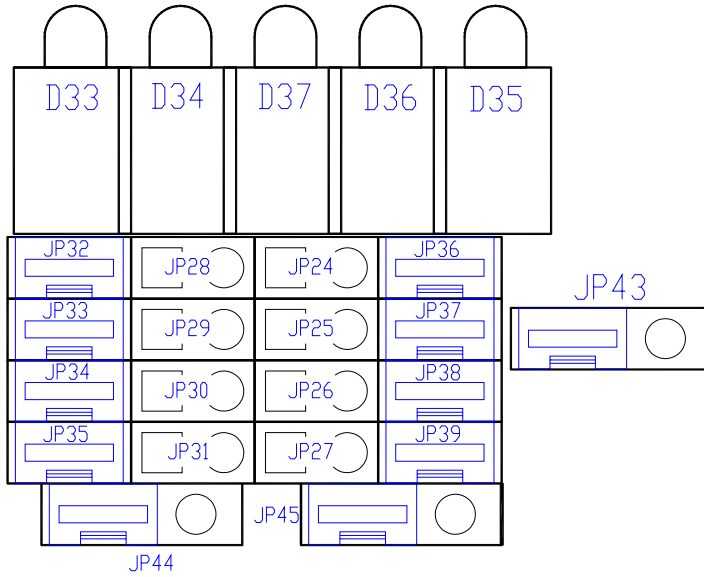

**Figure 1-7. Ethernet Configuration Jumpers for Rev B Boards**



**Note**

Jumpers **JP22**, **JP23**, **JP40**, and **JP41** are for internal use only.

- Rev B Board (see drawings and photos above). Jumper **JP42**. Adds a terminating resistor to the Detector port on this board. Jumpering pins 2-3 removes the

termination. This comes in the pull-down enabled position (jumper in place on pins 1-2).

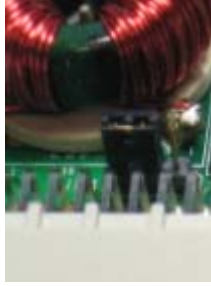

**Figure 1-8, JP42**

- Rev B Board. Jumper **JP43**. Adds a terminating resistor to the **TXD+** and **TXD-** signals on the Serial bus transmit pair. Jumpering pins 2-3 removes the termination. This comes in the terminated position (jumper in place).
  - Rev B Board. Jumper **JP44**. Adds a terminating resistor the **RXD+** and **RXD-** signals on the Serial bus receive pair. Jumpering pins 2-3 removes the termination. This comes in the terminated position (jumper in place).
  - Rev B Board. Jumper **JP45**. Adds a pull-down resistor to the **RXD-** signal of the Serial port. Jumpering pins 2-3 removes the termination. This comes in the terminated position (jumper in place).
3. Check that the voltage level to be provided to the RVT is correct. Voltage provided may range between 12 and 24 VDC (11 W maximum).
  4. *Disconnect the mains power to the power supply for the rack* in which the RVT will be installed. Check for no voltage.
  5. *Install the RackVision Backplane* to the back of the VME rack, using the four screws and insulating washers provided to attach each card to the rack. The standard DIN 41612, Type B, 64-pin connector (**J1**) should face the front of the rack. The SMA connectors and terminal blocks should face outwards from the rear of the Detector Rack with the SMA connectors at the bottom (See Figure 1-5, Rear View).
  6. *Connect the rack power supply wiring* to the **J4** power screw terminals. Voltage provided may range between 12 and 24 VDC. Positive voltage is connected to **V+** and Supply **GND** is connected to **V-**. For 64-pin RackVision Backplane pinout information, see Table 1-7.
  7. *Optional-Only needed if using a Detector Port Master. Configure the RackVision backplane slot number.* Configure the jumpers on **J5** to define the slot in which the RackVision Terra is installed. **J5** represents a 4-bit binary number. The presence of a jumper is considered to be a 0 in that bit location of the number. The absence of a jumper is considered to be a 1 in that bit location of the number. Thus, all four jumpers in place means 0 (binary 0000) and all four jumpers removed means 15 (binary 1111). The RVT software converts the **J5** jumper settings (values 0 thru 15) to sensor numbers by adding 1 to the binary jumper number (i.e., to get 1 through 16). The valid sensor numbers are 1 through 15.

Note that the value, 16, (all **J5** jumpers removed) is not valid as a value in the Detector Port Protocol. So for proper function, at least one jumper must be present.

For **J5** pinout information, see Table 1-11 and the accompanying figures that match jumper placement with sensor numbers. The maximum number of RVTs that can be bussed together with one Detector Port Master is 1 for Rev A boards, and 8 for Rev B

boards. The Rev B boards have a jumper (**JP42**) that allows up to 8 Rev B boards and a Detector Rack Card on the bus. For larger numbers of RVTs, more than one Detector Port Master must be used.



**Note**

The RackVision Terra can handle either PAL or NTSC video formats. Further, it can automatically sense the video format when the video is applied to the video input. If the RVT powers up and does not find video at its Video inputs, then after 30 minutes, it will automatically reboot to ensure that no hardware or software issue is preventing proper detection of the video. This process will repeat until a valid video input is found.

8. *Video In SMA/BNC Adapter cable.* Connect the SMA end of the SMA-to-BNC adapter cable to the **J6 Video In** connector. Connect the BNC end of the adapter cable to the coaxial cable that comes from either the fiber optic transceiver or the transient-protected coaxial cable connected to the AIS camera or CCTV camera. For transient device details and installation information, see Providing Video Signal Transient Protection for Coaxial Cable Connections later in this section.
9. *Video Out SMA/BNC Adapter cable.* Connect the SMA end of the SMA-to-BNC adapter cable to **J7 Video Out** connector. Connect the BNC end of the adapter cable to the BNC connector on the coaxial cable that goes to a video device such as a video switch or television monitor.



**Note**

If the **J8** connector will be used to bus AC interrupt signals between RackVision Terra units, step 10 below can be skipped.



**Caution**

**Hazard of equipment damage.**

**J3 Pin 5 (AC Interrupt)** permissible voltage level is 0 to +5 VDC. Do not connect a controller input or output signal with higher voltage to this pin.

10. *Connect AC Interrupt to provide clock synchronization signal to RackVision Terra.* The RackVision Terra Euro Model does not have on-board circuitry to extract a clock synchronization signal from the AC input voltage. If available, connect an AC interrupt signal from the Traffic Controller to **J3 Pin 5 (AC Interrupt)**, see Table 1-9. This signal has logic level voltages 0 to +5 VDC. For customers using the AC interrupt with Rev A boards, please contact your local Autoscope technical support specialist or Autoscope Technical Support at [support@imagesensing.com](mailto:support@imagesensing.com) for important details regarding the use of the AC Interrupt.
11. If using more than one Terra board in this installation, connect each board to a customer supplied Ethernet Switch, using standard CAT-5 patch cables. Connect a patch cable from each Terra board to one port on the Ethernet switch until all the Terra boards are connected.
12. If additional RVT units are to be installed, repeat the above steps 3 through 10. Otherwise, you can now apply power to the RackVision Terra and verify its proper operation.

13. Connect the active RJ-45 Ethernet port on the Rack Vision Terra to the customer supplied Ethernet Router or Switch. Use standard CAT5 patch cables with RJ45 connectors on each end, from each Rack Vision Terra board to one port on the Ethernet Router or Switch. Repeat for each Rack Vision Terra and verify operation by observing the **Link** light is glowing on the Ethernet Switch (or Router) once power is applied.

---

### Applying Power to the RackVision Terra and Verifying Proper Operation

1. *Connect Power.* When all connections are completed, reconnect mains power to the rack power supply.
2. *Verify connections.* To verify proper wiring, you may observe proper operation once the RackVision detector file is configured.
3. *Further assistance.* Please contact your local Autoscope technical support specialist or Autoscope Technical Support at [support@imagesensing.com](mailto:support@imagesensing.com) if you have any questions or concerns.

---

### Connecting RackVision Terra On-Board Inputs and Outputs to a Traffic Controller

1. *Disconnect the mains power to the power supply for the rack* in which wiring will be modified. Check for no voltage.
2. *If you are passing detector outputs to a traffic controller,* connect wires from the **J2** screw terminals to the corresponding controller inputs. For pinout information, see Table 1-8. For further information, see How RackVision Terra Inputs and Outputs Work after this procedure.
3. *If you are receiving controller signal inputs,* connect wires from the controller signal outputs to the corresponding **J3** input terminal block. For **J3** pinout information, see Table 1-10. For further information, see How RackVision Terra Inputs and Outputs Work after this procedure.



**Note**

The signals from the controller should be logical voltages (0 to **V+** VDC). For location of **V+** terminal, see Figure 1-13, **J4** connector.



**Caution**

**Hazard of equipment damage.**

**J3** Pin 5 (**AC Interrupt**) permissible voltage level is 0 to +5 VDC. Do not connect a controller input or output signal with higher voltage to this pin.

4. *Connect Power.* When all connections are completed, reconnect mains power to the rack power supply.
5. *Verify connections.* To verify proper wiring, you may observe proper operation once the RackVision Terra detector file is configured or use the Autoscope Software Suite's Autoscope System Tests application to manually activate each detector output in turn and to verify that the controller receives the proper output signal.
6. *Further assistance.* Please contact your local Autoscope technical support specialist or Autoscope Technical Support at [support@imagesensing.com](mailto:support@imagesensing.com) if you have any questions or concerns.

## How RackVision Terra Inputs and Outputs Work

Outputs from the RackVision Terra are transistor equivalents and may be treated as contact closures within their operating range, provided that the proper polarity is maintained. Outputs turn **ON** (contacts close) when the corresponding MVP detector is active.

Interfaces with typical controller connections and pilot relays are shown. The RackVision Terra boards do not have the 10K resistor to **V+** that was present in earlier non-Terra designs. The voltage used for the relays must not exceed the voltage applied to the RackVision Terra board at all times.



### Note

The diode (1N4002 or equivalent) across the relay coil is **required**. This is used to suppress the voltage transient created when the pilot relay is turned off.

Electrical connection options are shown below:

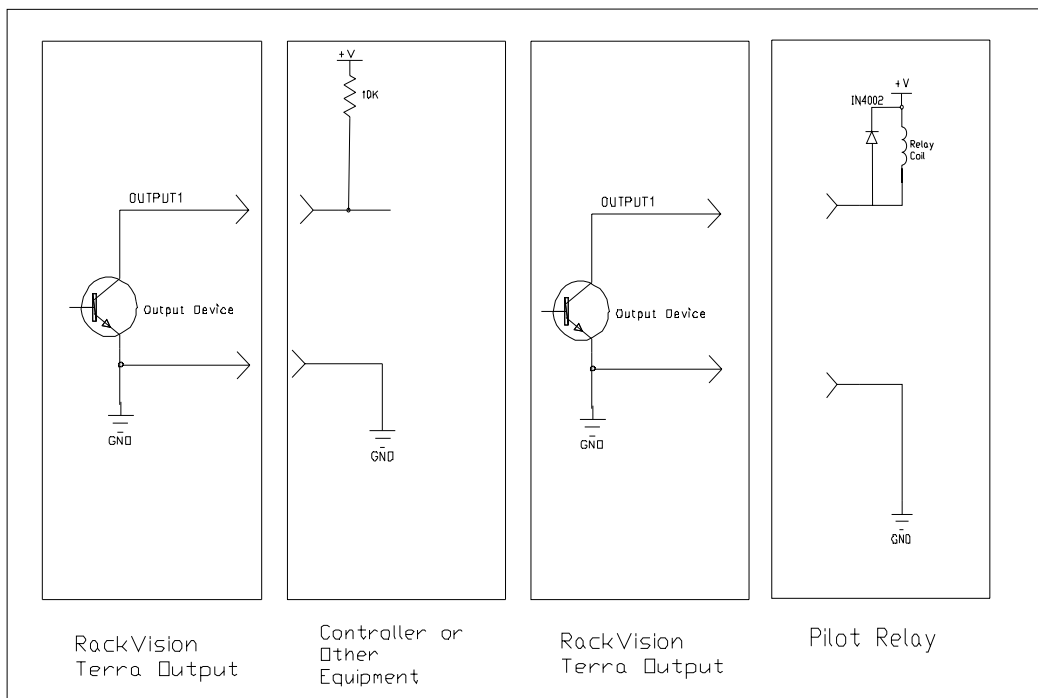

**Figure 1-9. Local Output Connections**

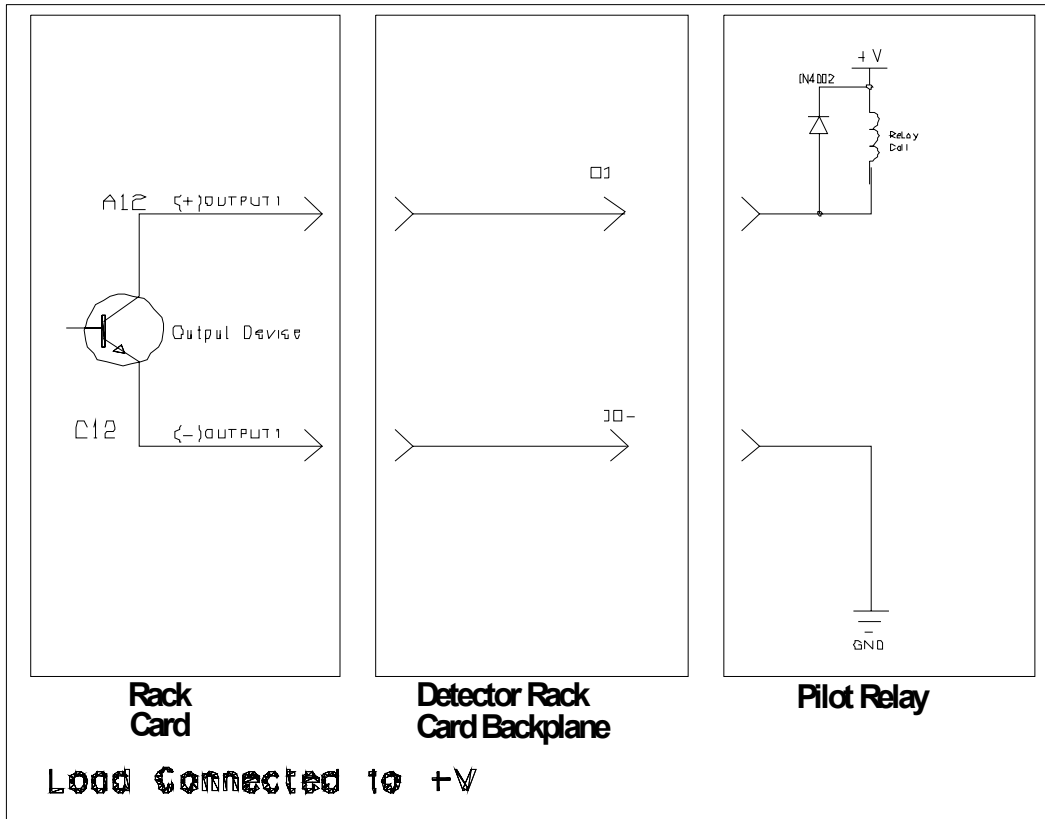
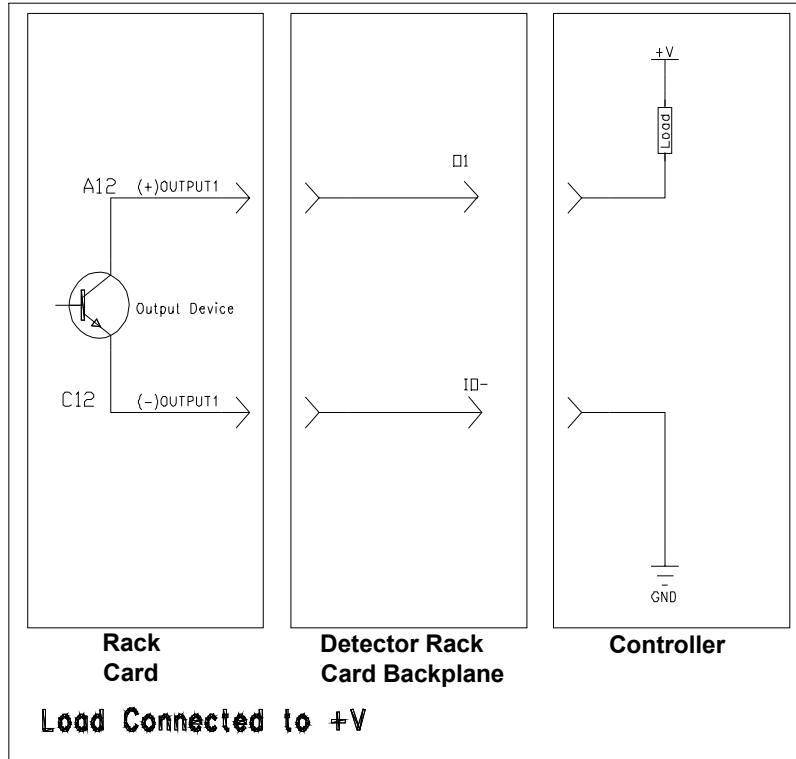
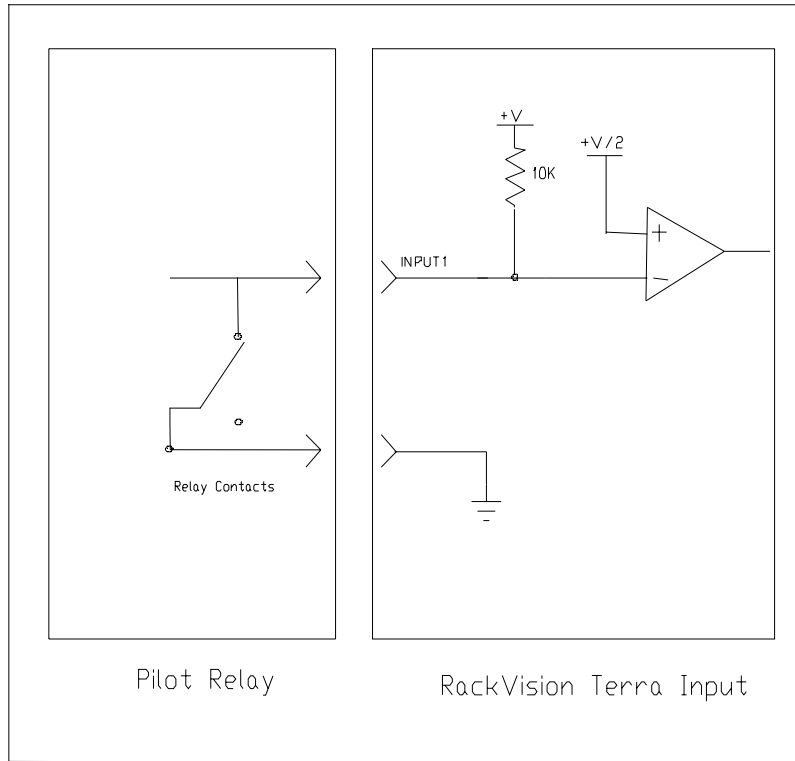
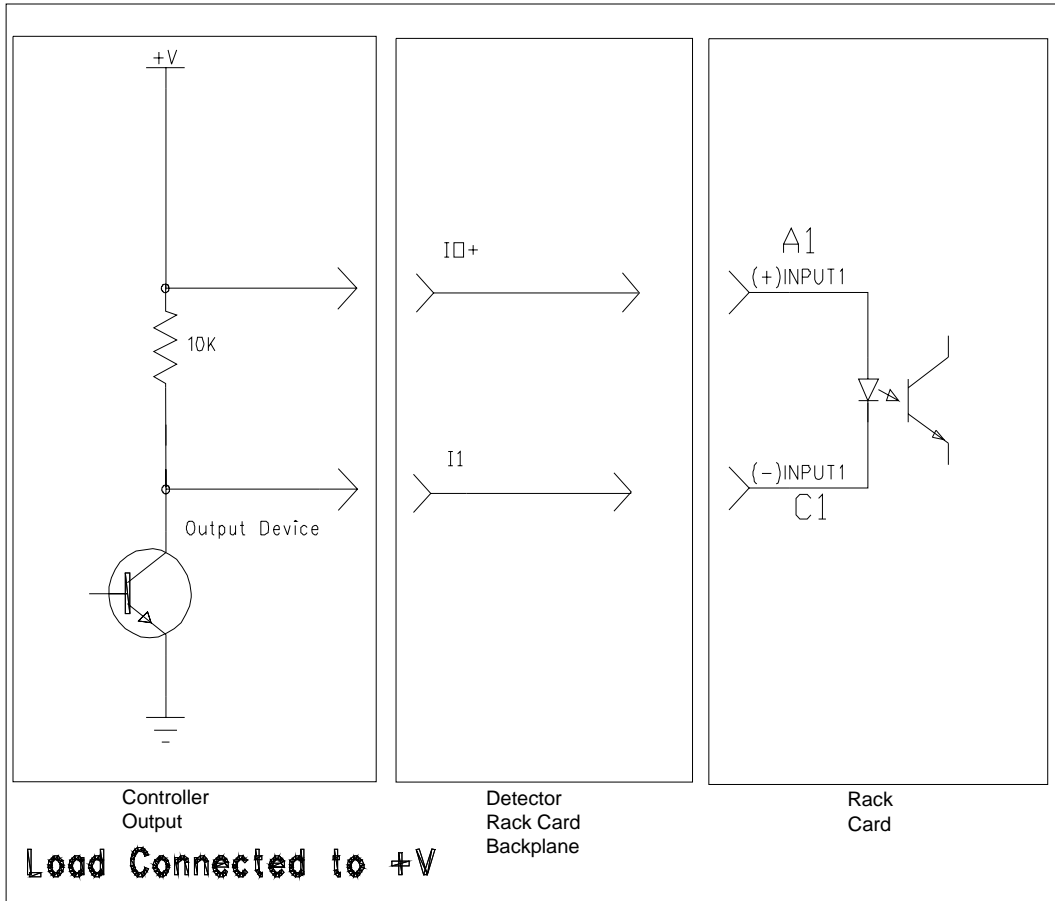

Figure 1-9a. Output Connection Options With Detector Rack Card

Inputs to the RackVision Terra are voltage activated. Applying a voltage of less than  $\frac{1}{2}$  of the supply voltage to an input will activate that input for active low logic. Note that the threshold is shown as  $V+$  divided by two, however this threshold is programmable by **J12**, which allows for the Terra card operating at a different voltage from the interfacing equipment. **J12** settings should match the signal range of the interfacing equipment. Connection examples are shown below.



**Figure 1-10. Local Input Connections**



**Figure 1-10a. Input Connection Options With Detector Rack Card**

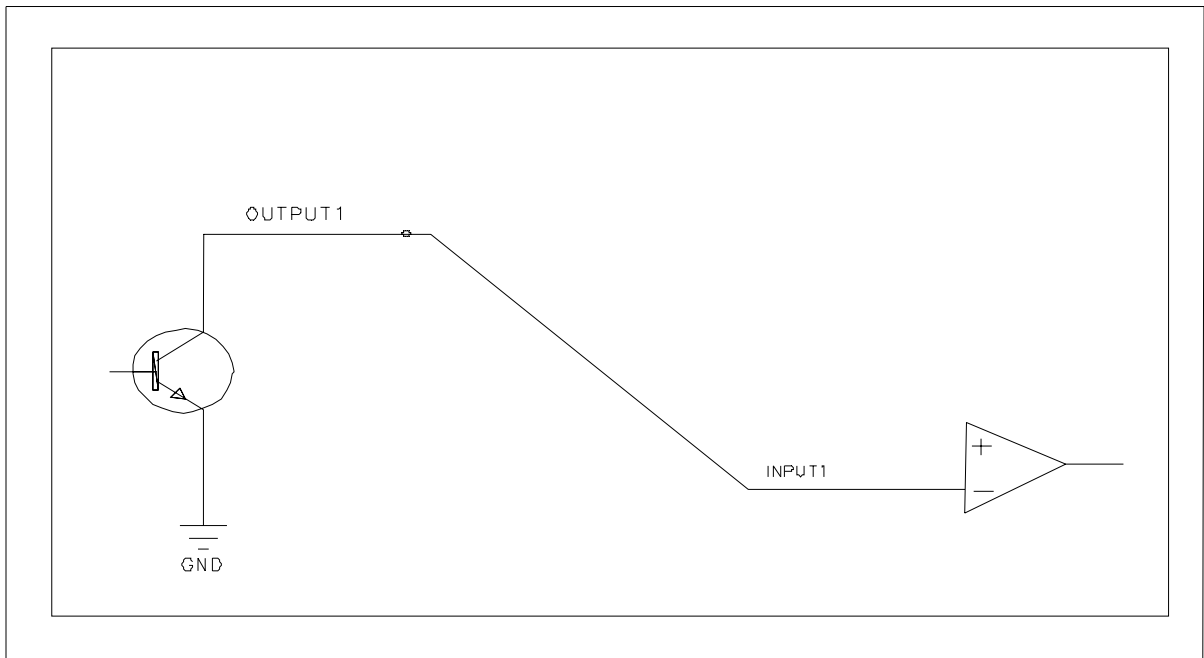

**Figure 1-11. Local Loopback Testing**

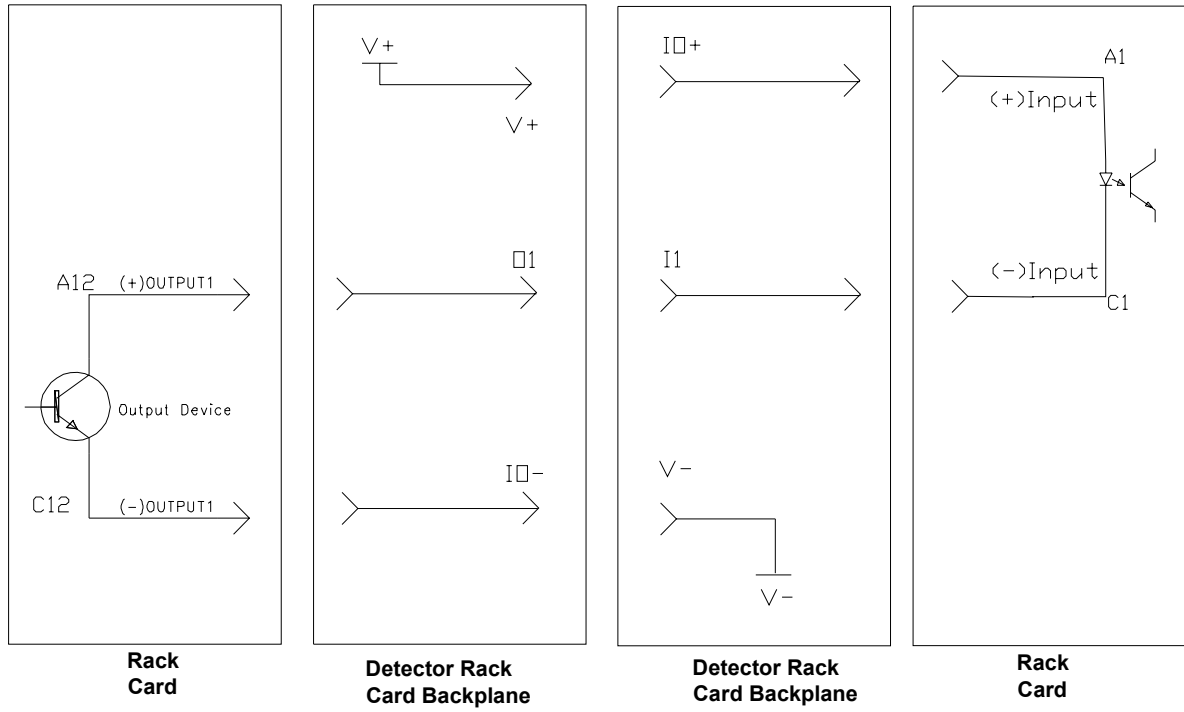

**Figure 1-11a. Loopback Testing Option With Detector Rack Card**

---

## Communications for Bussing Multiple RackVision Units



**Note**

If you are making Ethernet connections, you may network multiple RVTs together using an RJ-45 connector from the front panel to an Ethernet switch and then, using the switch, route the input signals to the network.

To buss multiple RackVision Terra units:



**Note**

If you need to buss more than 32 RackVision Terra units together, please contact your local Autoscope technical support specialist or Autoscope Technical Support at [support@imagesensing.com](mailto:support@imagesensing.com), to verify that the approach you are intending to use is optimal.

1. *Disconnect the mains power to the power supply for the rack* in which wiring will be modified. Check for no voltage.
2. *To create a communications buss between multiple RackVision Terra cards*, connect a ribbon cable and connectors to each **J8** 2 × 5 header on the back of each RackVision Backplane. For **J8** pinout information, see Table 1-14.



**Note**

Pin 1 of **J8** can be identified as the pin that has the square solder pad on the circuit board. Additionally, the side of the connector on the backplane, next to pin 1, has an embossed arrow. The ribbon cable is a straight-through cable.



**Note**

All of the signals of **J9** (reserved for future use) and **J10** (Detector Port) are contained in **J8**. In the absence of a ribbon cable, **J10** can also be used to create the bus. If this approach is taken, wire the appropriate twisted pair wires between the **J10** network connector terminal blocks on this backplane to those of another backplane, connecting like signals to one-another, e.g. **SR+** to **SR+** until all connections are complete.

For **J9** pinout information, see Table 1-15. For **J10** pinout information, see Table 1-16. For a multiple RackVision connection figure, see Figure 1-13. For RackVision-to-RackVision connections, use Table 1-6.



**Note**

When using **J10** to connect two RackVision Terra units together, it is not necessary to twist the wires in each pair together unless the separation between the two units is greater than 60 cm (2 ft). If the separation between two connected units is greater than this distance, twist the wires in each pair at a rate of about 1 full twist per 2.5 cm (1 in).

**Table 1-6. RackVision Backplane to RackVision Backplane Connection (J10 Terminal Block)**

Previous RackVision J10 Terminal		1 Twisted Wire Pair		Next RackVision J10-Terminal	
J10 Terminal Block		Terminal Pin #	Wire Color	Signal	Terminal Pin #
1 Twisted Pair:	D+	1	Yellow	D+	1
	D-	2	Black	D-	2



If you use more than 8 RackVision *Terras*, each set of 8 RackVisions requires an independent Detector Port bus.

**Note**

Using the Detector port requires that terminations be placed at the physical end of the bus cabling. This is often the Detector Rack Card on one end and the farthest Terra board on the other end.

**Note**

For Terra RackVision boards, Rev. A and earlier, only one RackVision and one detector rack card are supported on a bus. Terminations are pre-defined.

For Terra boards, Rev B and beyond—To accomplish proper terminations, leave **JP42** connected to pins 1-2 (default setting) on the end Terra board at the physical end of the chain. For all other Terra cards, move **JP42** to pins 2-3 (no termination) on all other cards using that bus.

The detector card has a permanent termination already installed and is physically located at the other end of the chain.

3. *Connect Power.* When all connections are completed, reconnect mains power to the rack power supply.
4. *Verify connections.* To verify proper wiring, you may observe proper operation once the RackVision Terra detector file is configured.
5. *Further assistance.* Please contact your local Autoscope technical support specialist or Autoscope Technical Support at [support@imagesensing.com](mailto:support@imagesensing.com) if you have any questions or concerns.

---

## Providing Video Signal Transient Protection for Coaxial Cable Connections

To provide video signal transient protection, the video must first go through an appropriate transient suppression device to avoid damage to equipment from a lightning strike or other transient. ISS recommends you use the EDCO CX06-BNCY Surge Suppressor or equivalent.

To install:

1. Plug in the connector labeled **EQUIP** to the BNC cable going to the RackVision Backplane **J6 Video In** connector. You connect the connector labeled **CABLE** to the BNC cable coming from the camera. Ground the Surge Suppressor to cabinet ground (earth ground) using the grounding point provided on the Suppressor.

It is important that the video cables be isolated from ground, thus not grounded at any other point in the system to prevent ground loops.



**Figure 1-12. Grounding Point**

## Connecting the RackVision Backplane to a Detector Rack Card

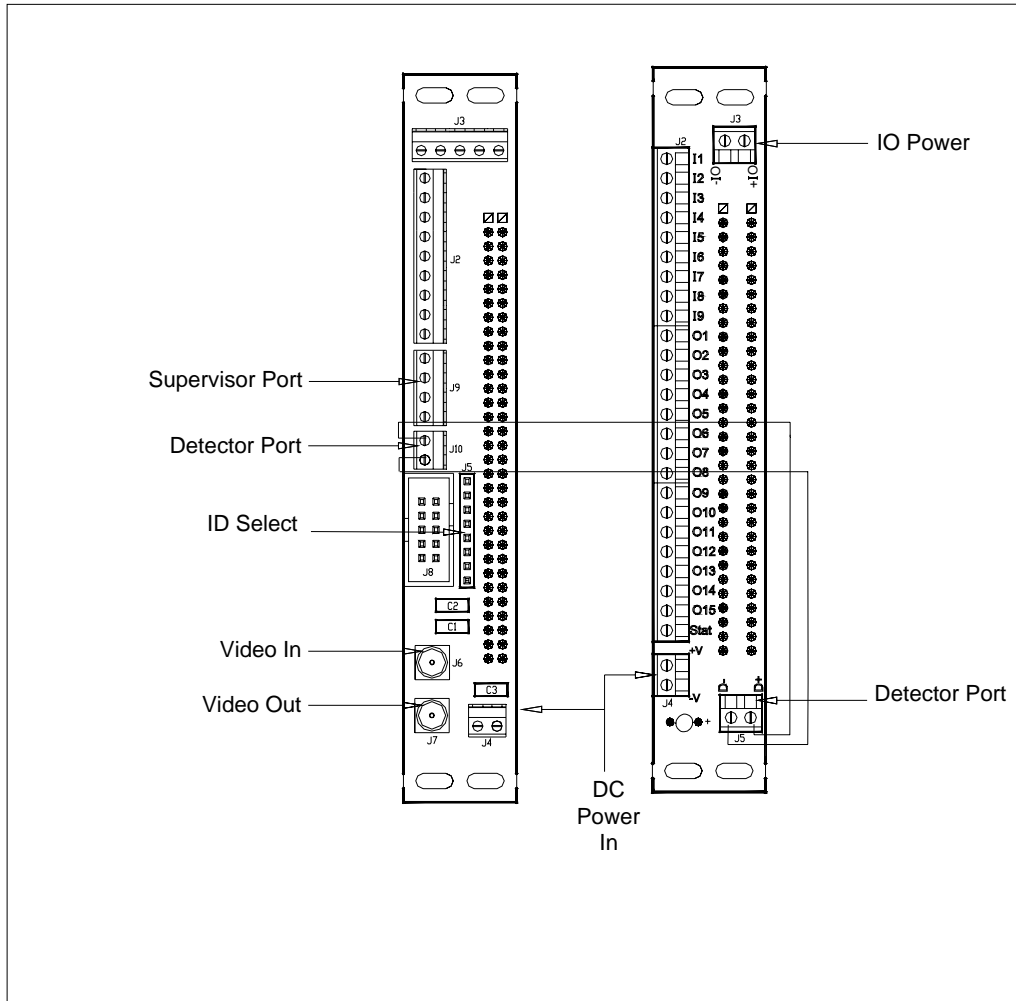

**Figure 1-13. Back View of the RackVision Backplane and Detector Rack Card Backplanes**



### Note

The Detector Rack Card does not handle Ethernet communications.

To connect the RackVision to a Detector Rack Card (Figure 1-13):

1. *Disconnect the mains power to the power supply for the rack in which wiring will be modified. Check for no voltage.*
2. *Install the Detector Rack Card Backplane to the back of the VME rack, using the four screws provided to attach each card to the rack. The standard DIN 41612, Type B, 64-pin connector (**J1**) should face the front of the rack. The terminal blocks should face outwards from the rear of the Detector Rack.*
3. *To connect RackVision Detector Port signals to the Rack Card, wire the detector port **J10 D+** and **D-** terminals on the RackVision Backplane to the **J5 D+** and **D-** terminals on the*

Detector Rack Card (DRC) Backplane. Connect **D+** to **D+** and **D-** to **D-**. If you are using multiple Rev A boards for connection to a Rack Card, please contact your local Autoscope technical support specialist or Autoscope Technical Support at [support@imagesensing.com](mailto:support@imagesensing.com). For pinout information, see Table 1-17.

4. *Connect Power.* When all connections are completed, reconnect mains power to the rack power supply.
5. *Verify connections.* To verify proper wiring, you may observe proper operation once the RackVision Terra detector file is configured or use the Autoscope Software Suite's Autoscope System Tests application to manually activate each detector output in turn and to verify that the controller receives the proper output signal.
6. *Further assistance.* Please contact your local Autoscope technical support specialist or Autoscope Technical Support at [support@imagesensing.com](mailto:support@imagesensing.com) if you have any questions or concerns.

## Networking RackVision Terra Using Serial Communications

The following two options may be used to connect together the RackVision Terra's Detector Port communications. If you are using multiple Rev A boards for connection to a Rack Card, please contact your local Autoscope technical support specialist or Autoscope Technical Support at [support@imagesensing.com](mailto:support@imagesensing.com). Choose the method that best suits your purposes.

The method shown in Figure 1-14 is recommended for wiring RackVisions together as you can easily snap on the ribbon cable and so avoid connecting numbers of individual wires.

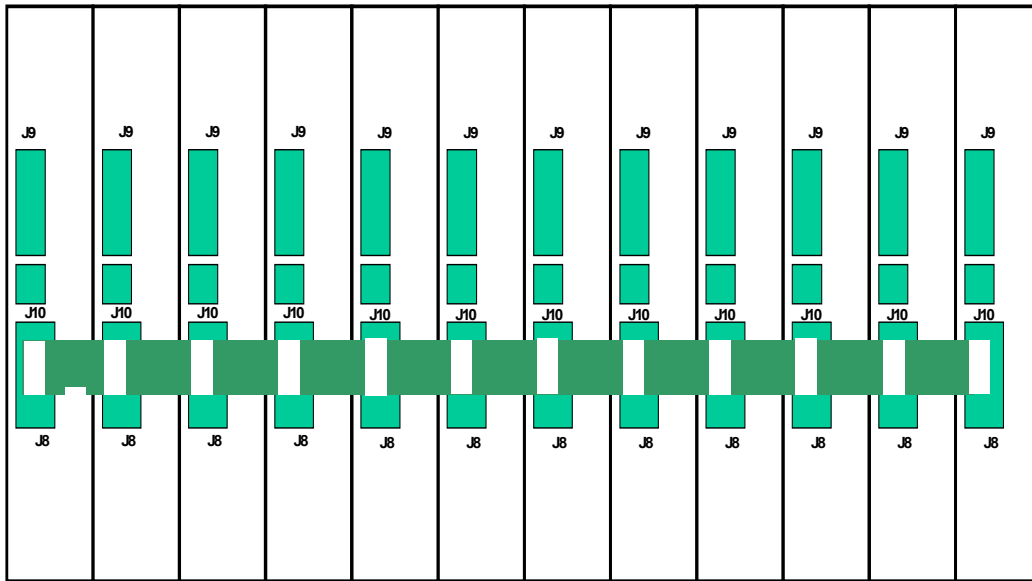

**Figure 1-14. Serial (Reserved for Future Use) Bus (RX+, RX-, TX+, TX-) and Detector Port Connections (D+, D-)**

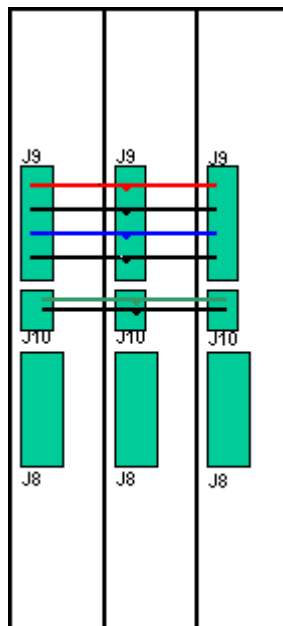

**Figure 1-15. J9 Serial Bus (Reserved for Future Use) (RX+, RX-, TX+, TX-) and Detector Port (D+, D-) Connections**



## RackVision Backplane Pinouts

Pinouts for the connectors for the RackVision Backplane are provided in this section: The 64-pin Male Connector **J1** provides the connector for the RackVision Terra to plug into on the RackVision Backplane (Table 1-7). The RackVision Backplane is mounted on a Detector Rack. Pinouts for the RackVision Terra area listed in the next section in Table 1-17:

**Table 1-7. RackVision Backplane Module Pinouts**

64-Pin Header Connector # (J1)	Backplane J1 Label	Backplane Description	64-Pin Header Connector # (J1)	Backplane J1 Label	Backplane Description
1	A1	Not Used	33	A17	OUT3
2	B1	GND	34	B17	Not Used
3	A2	RXD+	35	A18	Not Used
4	B2	GND	36	B18	Not Used
5	A3	OUT1	37	A19	VIDEO OUT+
6	B3	RXD-	38	B19	GND
7	A4	IN1	39	A20	OUT7
8	B4	Not Used	40	B20	VIDEO OUT-
9	A5	TXD+	41	A21	Not Used
10	B5	IN2	42	B21	IDENT1
11	A6	+5 VDC	43	A22	Not Used
12	B6	TXD-	44	B22	Not Used
13	A7	STATUS OUT	45	A23	GND
14	B7	PSCAINIT	46	B23	Reserved for future use
15	A8	IN3	47	A24	MODE
16	B8	Not Used	48	B24	OUT4
17	A9	GND	49	A25	DET+
18	B9	IN4	50	B25	Reserved for future use
19	A10	Not Used	51	A26	Not Used
20	B10	OUT2	52	B26	Reserved for future use
21	A11	GND	53	A27	Not Used
22	B11	GND	54	B27	Reserved for future use
23	A12	OUT5	55	A28	Not Used
24	B12	VIDEO IN-	56	B28	DET-
25	A13	VIDEO IN+	57	A29	Not Used
26	B13	OUT6	58	B29	IDENT2
27	A14	GND	59	A30	IDENT3
28	B14	Not Used	60	B30	+24 VDC
29	A15	Not Used	61	A31	OUT8
30	B15	Not Used	62	B31	IDENT4
31	A16	Not Used	63	A32	Not Used
32	B16	GND	64	B32	GND

Terminal Block **J2** provides 8 outputs with 1 status output. Assignments of detector output to

these pins are made via software configuration.

**Table 1-8. J2 Outputs/Status Terminal Block**

<b>9-Pin Detector Output Terminal Block</b>	
1	Output 1
2	Output 2
3	Output 3
4	Output 4
5	Output 5
6	Output 6
7	Output 7
8	Output 8
9	Status Output

Terminal Block **J3** provides 4 inputs. These inputs can be used for detector processing which is defined via logic level signals for intersection control. Red or Green signals are used to provide enhanced “smart” detector outputs.



**Caution**

**Hazard of equipment damage.**

**J3** Pin 5 (64-pin) (**AC Interrupt**) permissible voltage level is 0 to +5 VDC. Do not connect a controller input or output signal with higher voltage to this pin.

**Table 1-9. J3 Inputs/AC Interrupt Terminal Block**

<b>4-Pin Output Terminal Block</b>	
1	Input 1
2	Input 2
3	Input 3
4	Input 4
5	AC Interrupt

Terminal Block **J4** provides power connections.

**Table 1-10. J4 Power Terminal Block**

<b>2-Pin Power Terminal Block</b>	
1	+12 to 24 VDC
2	Logic GND

Header Connector **J5** provides the jumper settings for configuring the RackVision Terra slot

number. This is only needed if multiple RackVision cards are connected to the Detector Rack Card DPM. Then each RackVision card must be unique. This slot number corresponds to the Sensor number in the software configuration and on the Detector Rack Card.

**Table 1-11. J5 Board Identification Jumpers**

8-Pin Header Connector	
1	IDENT1
2	GND
3	IDENT2
4	GND
5	IDENT3
6	GND
7	IDENT4
8	GND

The RackVision backplane has two J5 configurations. Jumper placement for each sensor number is shown for both earlier and later configurations. Remember, 1 is added to each jumper position. So all four jumpers inserted generates Sensor Number 1.

Earlier versions of the RackVision backplane have the following J5 configuration:

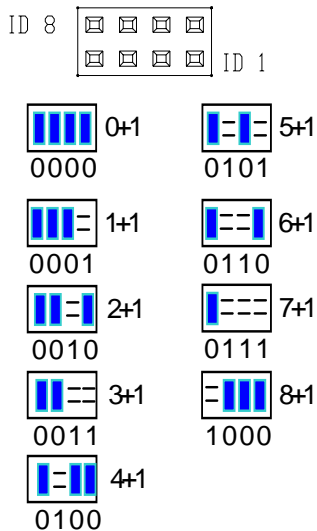

Later versions of the RackVision backplane have the following J5 configuration:

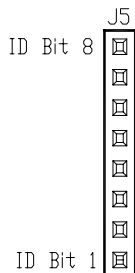

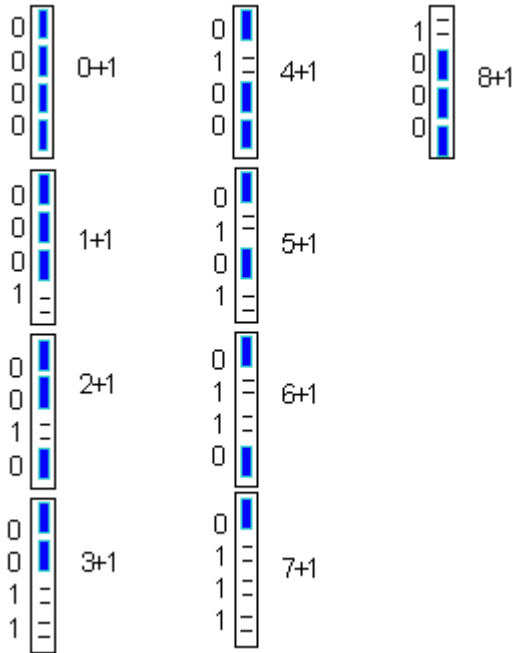

SMA mount **J6** provides the Video Input connector.

**Table 1-12. J6 SMA Video Input Connector**

2-Pin Video Input Connector	
1	VIDEO IN+
2	VIDEO IN-

SMA mount **J7** provides the Video Output connector.

**Table 1-13. J7 SMA PC Mount Video Output Connector**

2-Pin Video Output Connector	
1	VIDEO OUT+
2	VIDEO OUT-

Terminal Block **J8** is the bus connector for the Detector Port, Supervisor Port, and AC Interrupt signals.

**Table 1-14. J8 Bus Connector Signals**

Pin	Signal
1	J9 pin 1 RXD+
2	J9 pin 2 RXD-
3	J9 pin 3 TXD+
4	J9 pin 4 TXD-
5	GND
6	GND
7	GND
8	AC Interrupt
9	J10 pin 1 D+
10	J10 pin 2 D-

Terminal Block **J9** is the old Supervisor Port (now reserved for future use) connector (64-pin only).

**Table 1-15. J9 Serial Port (Reserved for Future Use) Pinouts**

Pin	Signal
1	SR+ (RXD+)
2	SR- (RXD-)
3	ST+ (TXD+)
4	ST- (TXD-)

Terminal Block **J10** is the Detector Port connector.

**Table 1-16. 64-Pin J10 Detector Port Pinouts**

Pin	Signal
1	D+
2	D-

## RackVision Terra Pinouts

RackVision pinouts are listed in the following Tables:

**Table 1-17. RackVision Terra Back Edge Connector Pinouts  
(64-Pin Connector is Columns A and B. 96-Pin Connector Includes Column C)**

Pin Number	Column A	Column B	Column C
1	Input 7	Logic Ground	Input 9
2	RXD+	Logic Ground	Input 10
3	Output 1	RXD-	Input 11
4	Input 1	Input 6	Input 12
5	TXD+	Input 2	Input 13
6	+ 5 VDC	TXD-	Input 14
7	Status Output	ACINT	Input 15
8	Input 3	Input 5	Input 16
9	Logic Ground	Input 4	Output 17
10	Input 8	Output 2	Output 18
11	Logic Ground	Logic Ground	Output 19
12	Output 5	Video In Y-	Output 20
13	Video In Y+	Output 6	Output 21
14	Logic Ground	Chassis Ground	Output 22
15	Output 9	Output 10	Output 23
16	Output 11	Logic Ground	Output 24
17	Output 3	Output 12	Output 25
18	Output 13	Output 14	Output 26
19	Video Output +	Logic Ground	Output 27
20	Output 7	Video Output -	Output 28
21	Output 15	Slot ID bit 1 (lsb)	Output 29
22	Output 16		Output 30

Pin Number	Column A	Column B	Column C
23	Logic Ground		Output 31
24	Mode Select	Output 4	Output 32
25	RS485 RXD / TXD +		Ethernet 1
26		I <sup>2</sup> C SDA	Ethernet 2
27		I <sup>2</sup> C SCL	Ethernet 3
28		RS485 RXD / TXD -	Ethernet 4
29	Reset In	Slot ID bit 2	Ethernet 5
30	Slot ID bit 3	+ Supply (10 - 30) VDC	Ethernet 6
31	Output 8	Slot ID bit 4 (msb)	Ethernet 7
32	Reserved	-Supply (10-30 VDC)	Ethernet 8

Front Panel Ethernet Port Pinouts:

**Table 1-18. RackVision Ethernet Port Pinouts**

<b>8-Pin Ethernet Port</b>	
1	TX+
2	TX-
3	RX+
4	Termination
5	Termination
6	RX-
7	Termination
8	Termination

Front Panel USB 2.0 Port Pinouts reserved for later use:

**Table 1-19. USB Type-A Connector Pinouts**

<b>Pin</b>	<b>Signal Description</b>
1	Reserved for future use.
2	Reserved for future use.
3	Reserved for future use.
4	Reserved for future use.

**Copyright 2005-2008 Image Sensing Systems, Inc. All Rights Reserved**

**No part of this document may be reproduced or quoted without written permission from Image Sensing Systems, Inc.**

**Autoscope is a United States registered trademark of Image Sensing Systems, Inc. Windows is a registered trademark of Microsoft Corporation. IBM PC is a registered trademark of International Business Machines.**

**All other product names are trademarks or registered trademarks of their respective owners.**